



AIRPLANES!



If you've ever wondered...

- What are the main parts of an airplane?
- What makes an airplane fly?
- How is an airplane controlled?
- What is the instrument panel?

...then this guide is for you!

Here you'll find answers to these questions, experiments to show you how airplane wings work, and puzzles.

If you want to learn more about aviation, see the resource list inside.

HAVE FUN!



Provided by the Aircraft Owners and Pilots Association

AOPA • 421 Aviation Way, Frederick, Maryland 21701 • 800-USA-AOPA

www.aopa.org/path • www.letsstoflying.com • ft.aopa.org

Pages may be photocopied for classroom/student use. Reprinted 06/10

THE MAIN PARTS OF AN AIRPLANE

1. Propeller
2. Landing gear
3. Right wing strut*
4. Wing
5. Right wing aileron
6. Right wing flap
7. Fuselage
8. Horizontal stabilizer
9. Vertical stabilizer
10. Rudder
11. Elevator
12. Left wing flap
13. Left wing aileron
14. Door
15. Fuel tanks
16. Windshield
17. Engine cowling

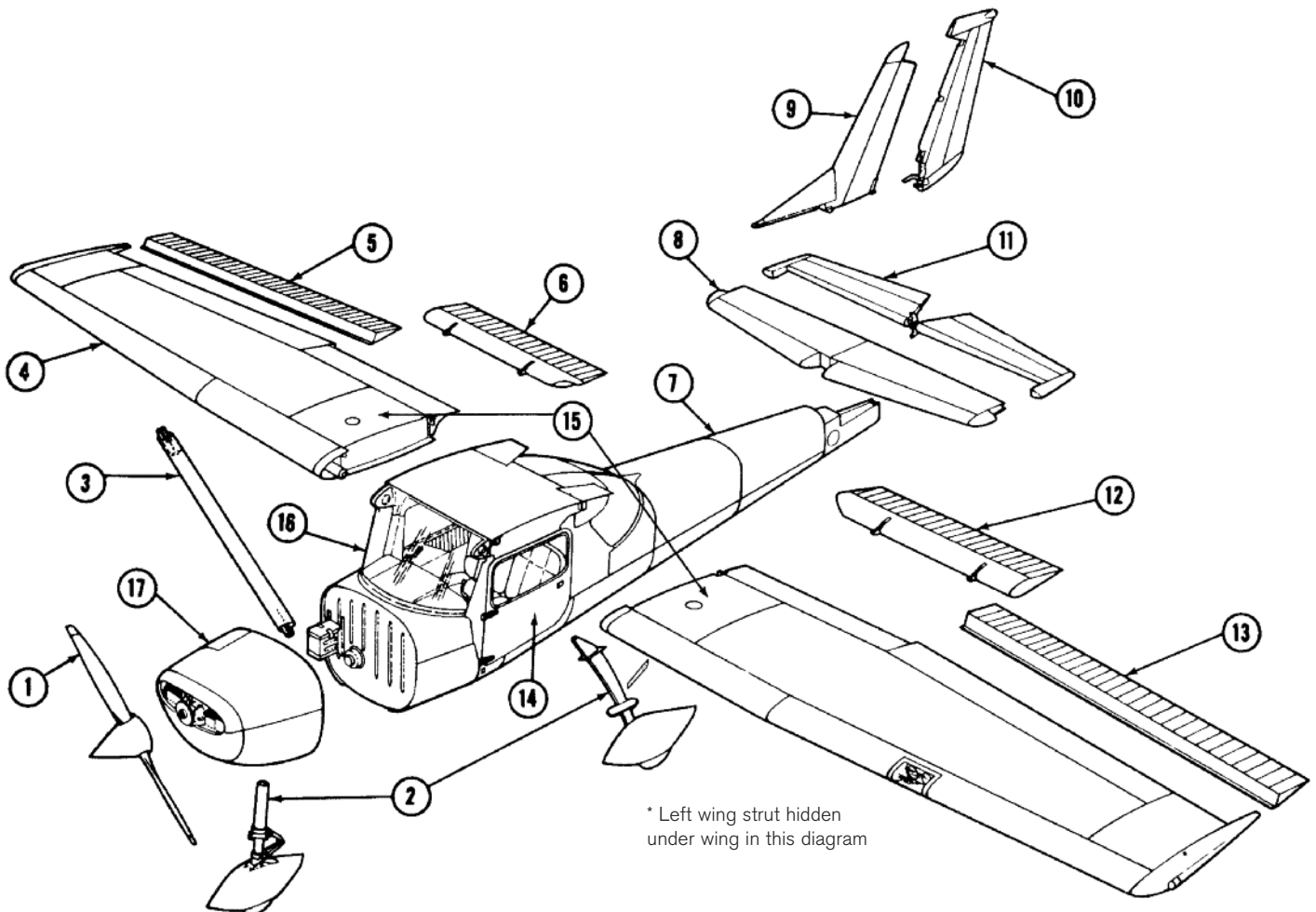

PARTS OF AN AIRPLANE THAT MAKE IT FLY

Propeller – A propeller is a rotating blade on the front of the airplane. The engine turns the propeller, which creates thrust to move the airplane forward through the air.

Wings – Wings are the parts of airplanes that provide lift. They also support the weight of the airplane and its contents while in flight.

Flaps – Flaps are the movable sections of an airplane's wings that are closest to the fuselage. They move in the same direction on both wings at the same time, and, by creating drag and lift, enable the airplane to fly more slowly when approaching to land.

PARTS OF AN AIRPLANE THAT HELP CONTROL DIRECTION OF FLIGHT

Ailerons – Ailerons are the movable sections on the outer edge of the airplane's wings. They move in opposite directions (when one goes up, the other goes down). They are used in making turns by controlling movement around the **longitudinal axis** (an invisible line through the airplane from the nose to the tail).

Rudder – The rudder is the movable, vertical section of the tail that controls lateral (side-to-side) movement around the **vertical axis** (an invisible line through the airplane from top to bottom). When the rudder moves in one direction, the aircraft nose moves the same direction.

Elevator – The elevator is the movable, horizontal section of the tail that causes the airplane to climb and descend. When the elevator moves one direction, the nose moves in the same direction (up or down). This movement is around the **lateral axis** (an invisible line that runs from wing tip to wing tip).

OTHER PARTS OF AN AIRPLANE

Fuselage – The fuselage is the central body of an airplane, designed to accommodate the pilot(s) and the passenger(s) and/or cargo.

Cockpit – The cockpit is the area at the front of the fuselage where the pilot sits and controls the airplane.

Landing gear – The landing gear is underneath the airplane and supports it while on the ground. The landing gear usually includes two main wheels and a nose- or tailwheel.

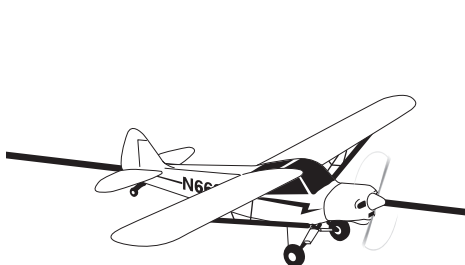

Longitudinal axis

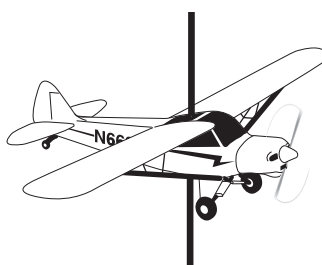

Vertical axis

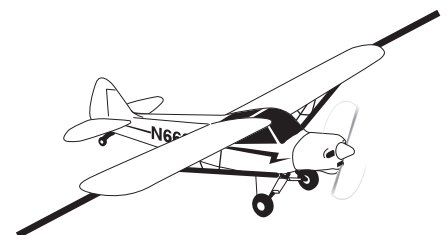

Lateral axis

INSTRUMENT PANEL

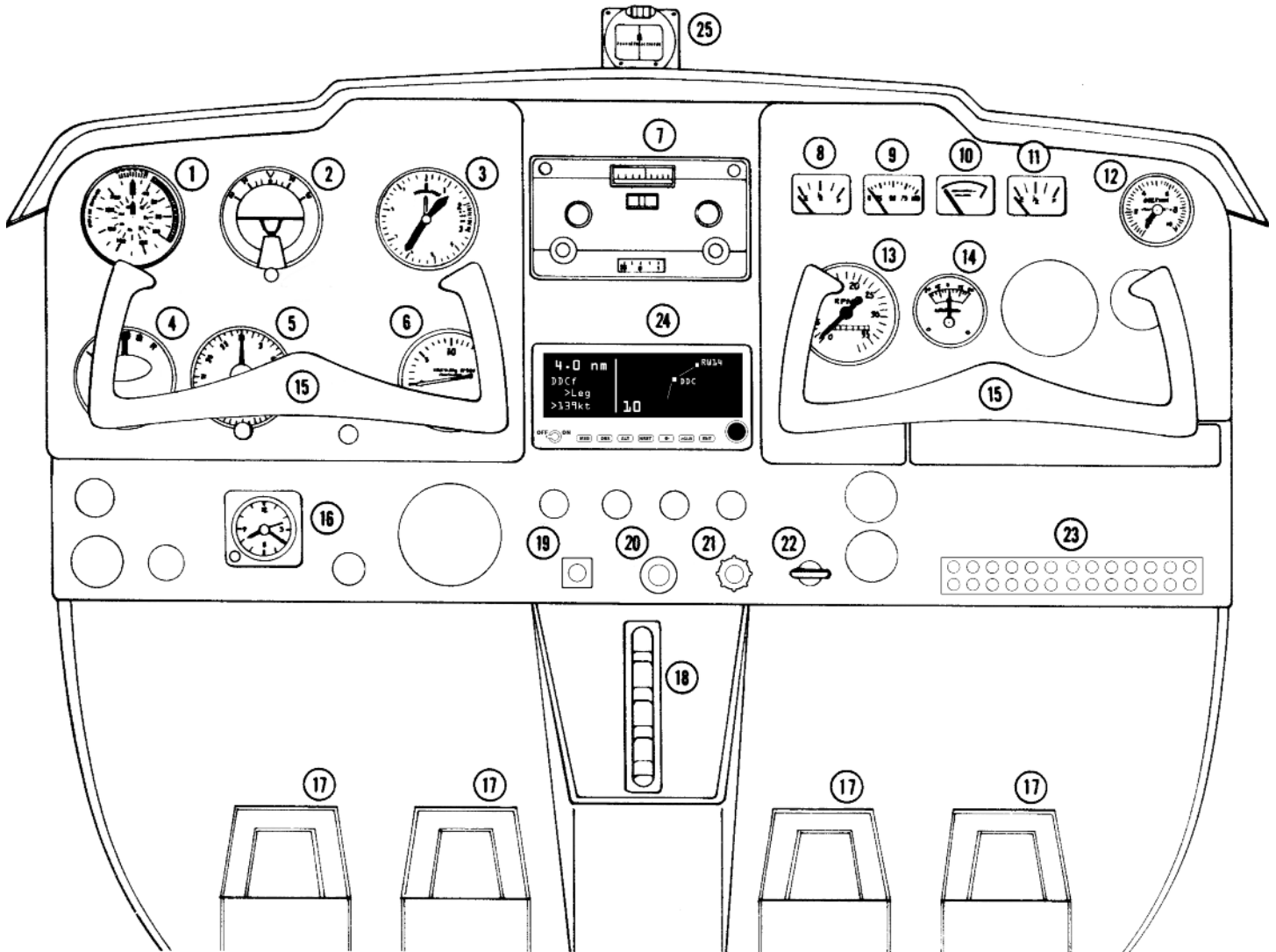

- | | | |
|---|---|---|
| 1. Airspeed indicator | 10. Oil temperature gauge | 16. Clock |
| 2. Attitude indicator | 11. Fuel gauge (right tank) | 17. Rudder pedals and brakes |
| 3. Altimeter | 12. Suction gauge (monitors vacuum pump for flight instruments) | 18. Trim tab control |
| 4. Turn coordinator | 13. Tachometer (measures revolutions per minute of propeller) | 19. Carburetor heat control |
| 5. Heading indicator | 14. Battery-generator indicator | 20. Throttle control |
| 6. Vertical speed (rate-of-climb/descent) indicator | 15. Control wheel (dual) | 21. Fuel-air mixture control |
| 7. VHF navigation-communication radio | | 22. Wing flaps control |
| 8. Fuel gauge (left tank) | | 23. Circuit breaker panel |
| 9. Oil pressure gauge | | 24. GPS receiver (for satellite navigation) |
| | | 25. Magnetic compass |

WHAT MAKES AN AIRPLANE FLY?

An airplane's movement is affected by the *four forces of flight*:

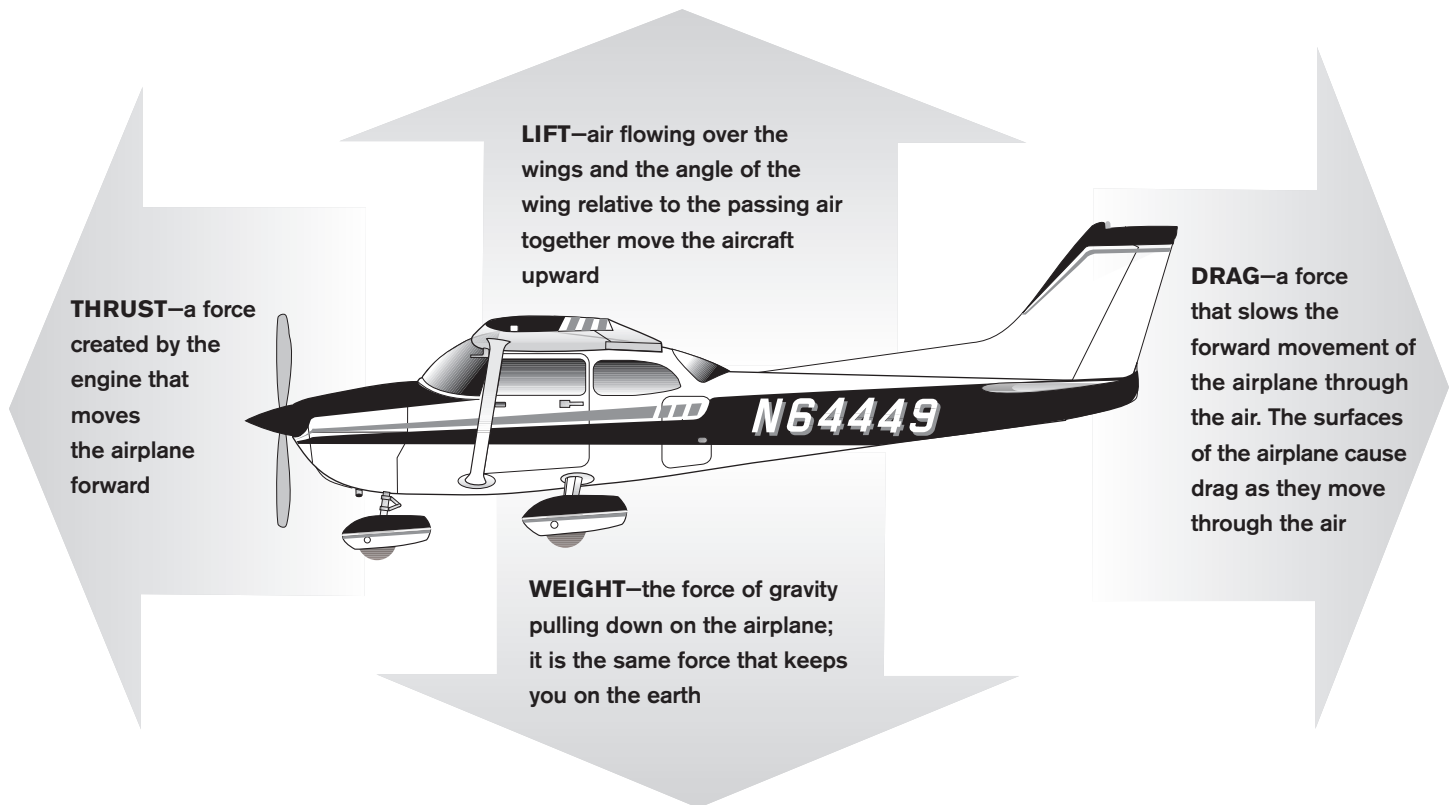

HOW IS AN AIRPLANE CONTROLLED?

TEACHERS:

From this activity, students will learn how control surfaces—the moving parts on the wing and tail—affect which way an airplane turns and moves through the air.

MATERIALS:

Sheet of paper
Paper clips
Room to throw

TO DO IT:

Folded Paper Airplane

1. Fold paper in half lengthwise and crease.
2. Fold down the corner of one side so the edge is even with the folded side of your original crease. Flip paper over and repeat to form a point.
3. Fold down the angled edge on one side so it is even with your original fold. Flip and repeat. You should now have a more narrow point.
4. Make a third fold that brings your new top edge even with the bottom of your original fold.
5. Push up the wings so they are perpendicular to the body of your airplane. Try launching your airplane.

Tip: If it seems "nose heavy," use paperclips near the rear of the airplane to add weight and help keep the nose up. You may need two or three paper clips.

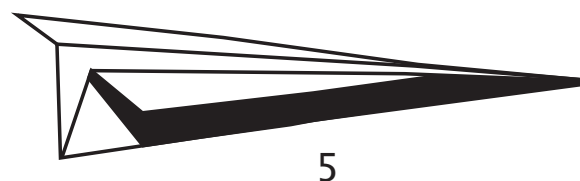
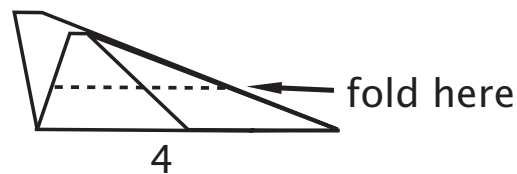
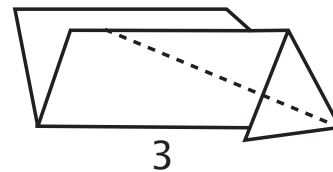
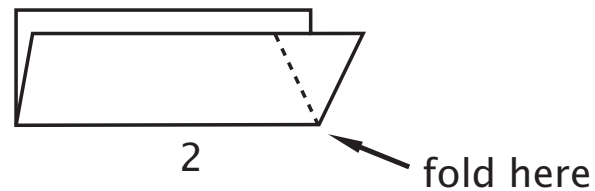
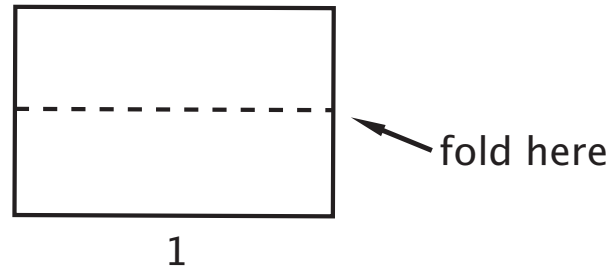

Control Surfaces – Up and Down

Once you have gotten your airplane to fly relatively straight, gently tear the back edge of each wing to create elevators. One-half to three-quarters of an inch should be enough.

Bend your elevators up slightly and see what impact it has on the flight path. Bend them down and try again.

Tip: Having the elevators in the down position should cause the nose to go down faster. Having them up should help your airplane climb and/or stay aloft longer.

Look for modest changes in float direction. The average paper airplane only stays aloft for a few seconds.

When the pilot wants the airplane to climb, he moves the airplane controls so that the elevators tilt up in the same way that you folded back the edges of your glider. The air hitting the elevators pushes the tail of the airplane down, tilting the nose upward, so the airplane can climb.

UP AND DOWN

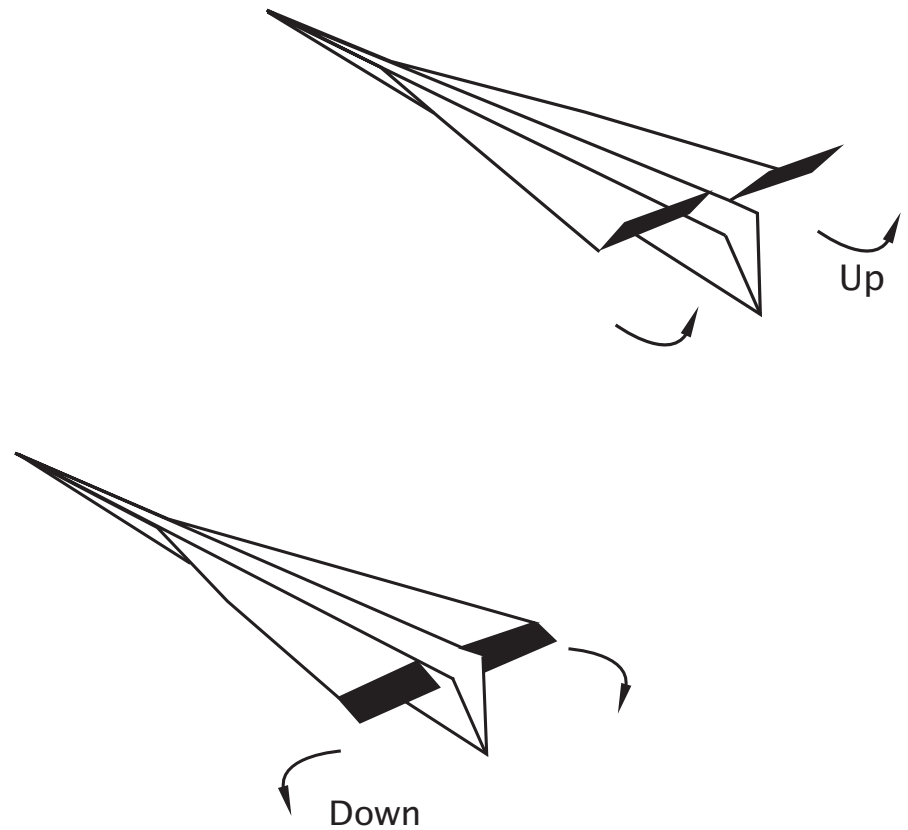

RIGHT AND LEFT

Control Surfaces – Right and Left

Now try the rudder or vertical fin. Tearing your elevators should have left you with a one-half to three-quarters inch portion of your airplane's body that can be folded left or right. Try folding it slightly left or right and test the impact on your airplane's flight path. Left or right folds should send your airplane left or right, respectively.

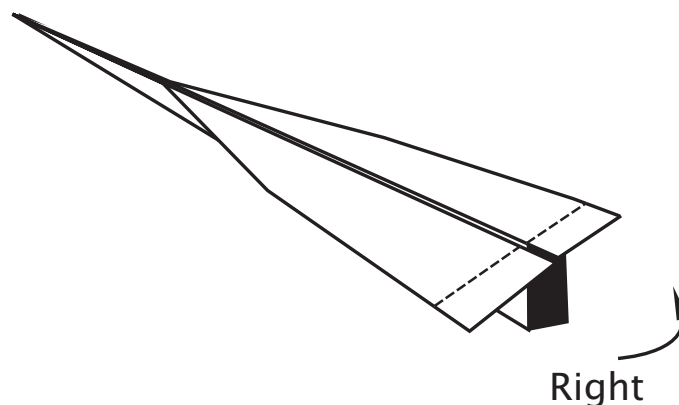

WINGS

Experiments to demonstrate how airplane wings work:

The force that lifts an airplane and holds it up comes in part from the air that flows swiftly over and under its wings.

Bernoulli's principle states that an increase in the velocity of any fluid is always accompanied by a decrease in pressure. Air is a fluid. If you can cause the air to move rapidly on one side of a surface, the pressure on that side of the surface is less than that on its other side.

Bernoulli's principle works with an airplane wing. In motion, air hits the leading edge (front edge) of the wing. Some of the air moves under the wing, and some of it goes over the top. Due to complex aerodynamic principles, the air moving over the top of the curved wing travels faster than the air moving under the wing. Therefore the air pressure on top of the wing is less than that on the bottom of the wing.

You can see **Bernoulli's principle** in action by experimenting with a strip of paper.

MATERIALS:

Strip of notebook paper or newspaper, about 2 inches wide and 10 inches long

A book

Paper clips

Make a wing by placing one end of the strip of paper between the pages of the book so that the other end hangs over the top of the book. Move the book swiftly through the air, or blow across the top of the strip of paper. It flutters upward. Hold the book in the breeze of an electric fan so the air blows over the top of the paper.

Take the strip of paper out of the book. Grasp one end of the paper and set it against your chin, just below your mouth. Hold it in place with your thumb and blow over the top of the strip. The paper rises. Try the same thing after you have fastened a paper clip on the end of the strip. See how many paper clips you can lift in this way.

Hold the strip of paper in your hands and run around the room. It doesn't matter whether you move the air over the strip of paper by blowing or whether you move the paper rapidly through the air—either way it rises.

PARTS OF AN AIRPLANE – WORD FIND

Find these words:

- Propeller
- Cockpit
- Fuselage
- Ailerons
- Rudder
- Elevator
- Wings
- Airplane
- Flaps
- Landing gear

B	C	O	P	D	Q	Q	W	V	F	X	V	L	H
U	A	P	V	R	I	R	K	M	L	Z	Y	A	M
T	S	N	H	J	O	E	F	V	A	G	A	N	H
W	G	C	O	C	K	P	I	T	P	N	Q	D	G
F	R	M	S	P	T	S	E	P	S	Z	O	I	I
X	L	K	R	F	U	S	E	L	A	G	E	N	J
Y	A	I	L	E	R	O	N	S	L	U	F	G	K
E	Z	J	N	O	W	V	E	L	Q	E	Y	G	J
R	U	D	D	E	R	D	R	P	A	L	R	E	D
H	I	Q	N	T	U	O	C	B	I	A	I	A	E
G	F	A	V	E	T	O	O	C	R	B	C	R	K
B	D	X	W	A	H	N	W	D	P	X	M	F	I
Z	Y	C	V	I	T	S	I	H	L	L	G	J	L
M	A	E	F	G	R	R	N	Q	A	P	O	P	M
B	L	D	E	X	A	S	G	I	N	K	L	N	J
E	C	W	Y	U	T	Z	S	J	E	K	L	B	K

Answer key:

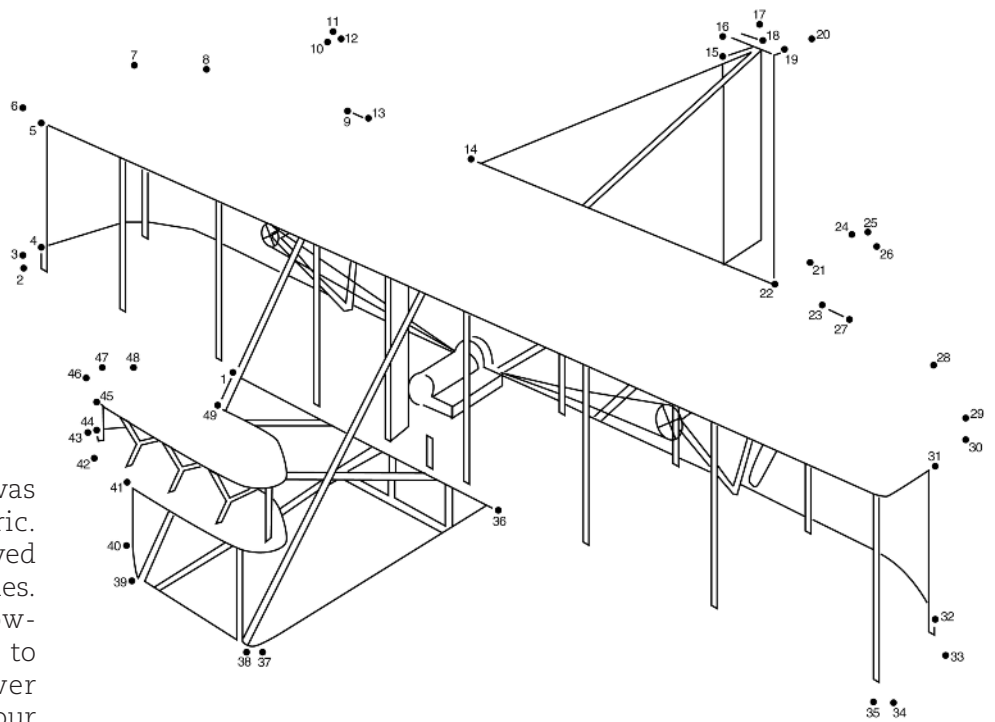

THE WRIGHT FLYER

The Wright Brothers' 1903 *Flyer* was a marvel of wood, wire, and fabric. The *Flyer's* drooping, slightly curved wings spanned 40 feet, four inches. It was powered by a 12-horsepower, 140-pound engine which sat to the right of center on the lower wing. The *Wright Flyer* flew just four times—a total of 98 seconds—all on December 17, 1903.

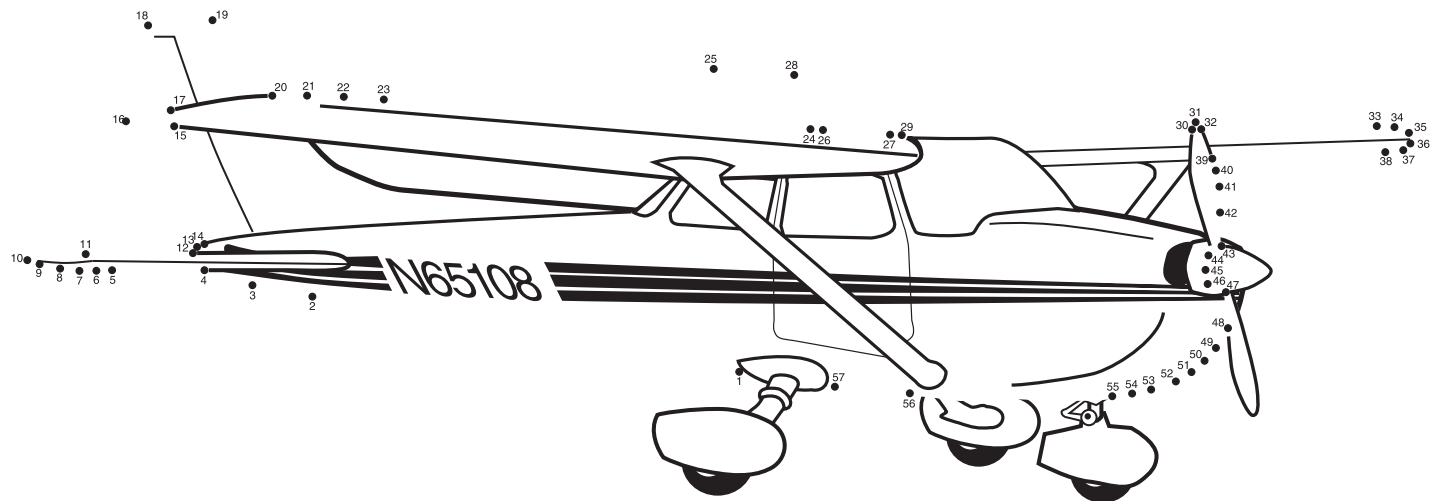

CESSNA 172

First introduced in 1956, the *Cessna 172* is one of the most popular and best-selling airplanes ever flown. Still in production, it is one of the most common airplanes used for training new pilots. The *Cessna 172 Skyhawk* was one of the first small airplanes

to have its third wheel in the front, under the nose, rather than under the tail. This “tricycle gear” was a new concept when Cessna first brought it to the market but it is now the standard configuration for modern training airplanes.

Web sites

www.aopa.org	Aircraft Owners and Pilots Association – thousands of pages of information from the world’s largest civil aviation organization
flighttraining.aopa.org	AOPA Flight Training – the only magazine dedicated to student pilots
www.nasa.gov/audience/forstudents/index.html	National Aeronautics and Space Administration’s pages and links for students
www.avkids.com	National Business Aviation Association’s “AvKids” program
www.faa.gov/education	Federal Aviation Administration’s educational resources
www.aviationeducation.org	National Coalition for Aviation Education – links to free materials
www.dot.gov/citizen_services/education_research/index.html	U.S. Department of Transportation (DOT) - information about transportation careers
www.scholastic.com/kids/	Scholastic is a global children’s publishing and media company

Books

Title	Author	Web site	Book number
Flights of Imagination (Ages 6-10)	Wayne Hosking	National Science Teachers Assoc. www.nsta.org	ISBN 0-87355-067-6
Usborne: Big Machines—Planes and Helicopters (Ages 5 & up)	C. Gifford	Usborne Publishing www.usborne.com	Hardback #1-58086-862-2
What’s a Piper Cub (Ages 4-8)	Jim Wheaton	www.historicaviation.com	Item # 0002640

Videos

Title/Run Time	Audience	Source	Contact	Cost
Let’s Go Flying DVD (54 minutes)	Middle and High School	King Schools, Inc. 3840 Calle Fortunada San Diego, CA 92123	www.kingschools.com click on “Takeoff Courses” 800-854-1001	\$49.00
Cleared to Land	Ages 4-6	Amazon.com	www.amazon.com (ASIN: 6303141935)	
Where Do Planes Sleep?	Ages 4-6	Amazon.com	www.amazon.com (ASIN: 6304551053)	

High Flight

Oh! I have slipped the surly bonds of earth
And danced the skies on laughter-silvered wings;
Sunward I've climbed, and joined the tumbling mirth
Of sun-split clouds - and done a hundred things
You have not dreamed of -
wheeled and soared and swung
High in the sunlit silence. Hov'ring there
I've chased the shouting wind along, and flung
My eager craft through footless halls of air.
Up, up the long delirious, burning blue,
I've topped the windswept heights with easy grace
Where never lark, or even eagle flew -
And, while with silent lifting mind I've trod
The high unsurpassed sanctity of space,
Put out my hand and touched the face of God.

*Pilot Officer John Gillespie Magee
No. 412 Squadron, Royal Canadian Air Force*



AIRCRAFT OWNERS AND PILOTS ASSOCIATION

421 Aviation Way • Frederick, MD 21701 • www.aopa.org